

# RBI Assistant Mains Practice Marathon Reasoning Set-02 (Solutions)

## Solutions (1-5):

Floor	Person	Place
6	O	Delhi
5	K	Noida
4	M	Gurgaon
3	J	Rewari
2	N	Jaipur
1	L	Agra

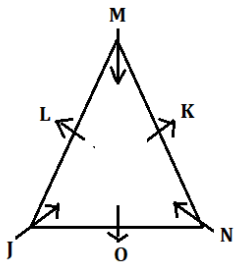

S1. Ans.(a)

S2. Ans.(d)

S3. Ans.(c)

S4. Ans.(e)

S5. Ans.(b)



## Solutions (6-10):

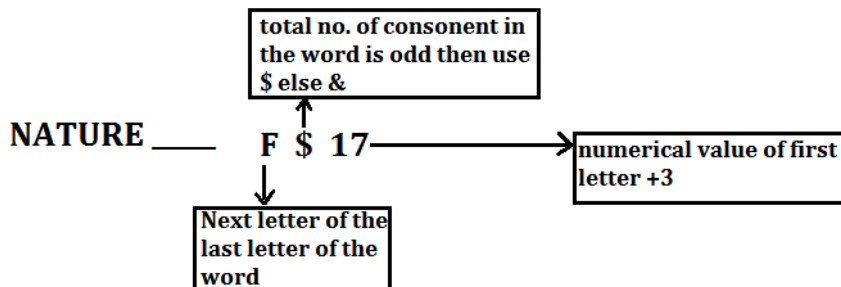

S6. Ans.(a)

S7. Ans.(b)

S8. Ans.(d)

S9. Ans.(b)

S10. Ans.(c)

TEST SERIES

**Bilingual**

Video Solutions

RBI ASSISTANT  
MAINS

25 Total Tests | eBooks

**Solutions (11-13):**

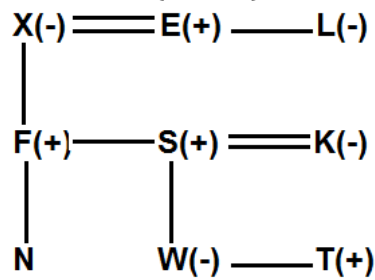

**S11. Ans.(d)**

**S12. Ans.(d)**

**S13. Ans.(d)**

**Solutions (14-15):**

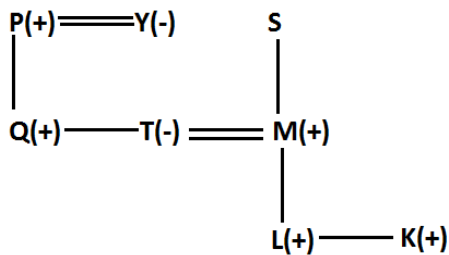

**S14. Ans.(e)**

**S15. Ans.(c)**

**S16. Ans.(b)**

**Sol.** Condition (i) and (iii) is applied = URGFAL - \$μ27μ\$

**S17. Ans.(d)**

**Sol.** Condition (ii) and (iv) is applied = MOPSBI - %@@%6%8

**S18. Ans.(a)**

**Sol.** Condition (ii) and (v) is applied = PUQEIA- μ%13&@

**S19. Ans.(e)**

**Sol.** Condition (iii) and (v) is applied = GBRFOL- 827#\$8

**S20. Ans.(c)**

**Sol.**

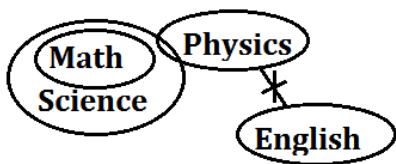

S21. Ans.(d)

Sol.

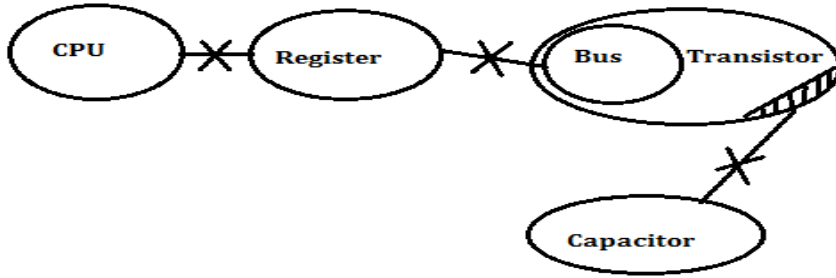

S22. Ans.(b)

Sol.

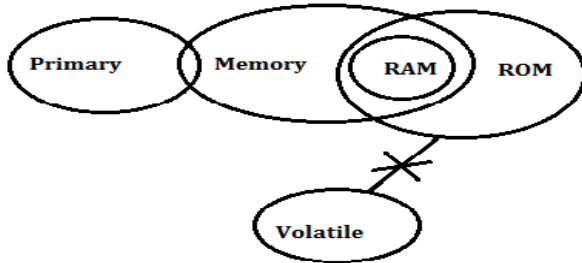

S23. Ans.(b)

Sol.

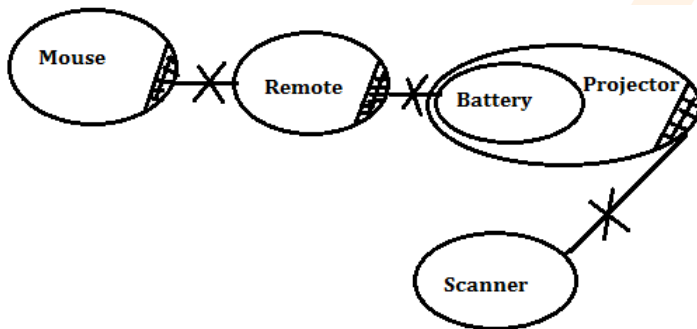

S24. Ans.(c)

Sol.

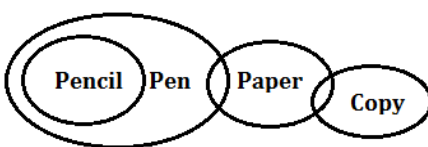

S25. Ans. (a)

Sol.

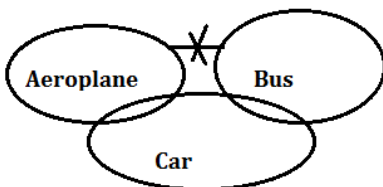

**BILINGUAL**

**adda247**

**CURRENT AFFAIRS**  
**CAPSULE BATCH** By Piyush Sir  
RBI ASSISTANT MAINS  
Starts March 16, 2020  
10 AM to 12 PM

### Solutions (26-30):

Let us understand the logic behind it-

- \* In Step-1, one is added in each even digit and three is subtracted in each odd digit of the input.
- \* In Step-2, All the numbers of step-1 arranged in descending order from left to right.
- \* In Step-3, Digits of the number are subtracted with in the number which are obtained in step-2.
- \* In Step-4, two is multiply by each odd digit and three is multiply by each even digit which are obtained in step-3.

**Input: 86 17 57 26 65 43 72**

Step I: 87 14 54 27 62 40 73

Step II: 87 73 62 54 40 27 14

Step III: 1 4 4 1 4 5 3

Step IV: 2 12 12 2 12 10 6

**S26. Ans.(a)**

**S27. Ans.(b)**

**S28. Ans.(c)**

**S29. Ans.(a)**

**S30. Ans.(e)**

### Solutions (31-35):

Box	Colour
G	Red
B	Orange
D	Pink
C	Grey
E	Blue
A	White
H	Green
F	Yellow

**S31. Ans.(e)**

**S32. Ans.(c)**

**S33. Ans.(d)**

**S34. Ans.(c)**

**S35. Ans.(b)**

**S36. Ans.(a)**

**Sol.** Because of the statement (B), government has decided to roll back the hike in the prices of cooking gas and kerosene.



**S37. Ans.(b)**

**Sol.** As he found cockroaches in the crevices, he immediately drew the attention of the catering manager. So, statement (B) is the effect of statement (A).

**S38. Ans.(d)**

**Sol.** Careful

**S39. Ans.(e)**

**Sol.** Original Number- 48623957

After arrangement- 23456789

Obtained number- 45674567

**S40. Ans. (d)**

**General Awareness**

Based on GA POWER CAPSULE

**RBI ASSISTANT MAINS**

 **bankersadda.com**

2500 + Questions  
Current Affairs | Banking | Static



**BOOKS**



Visit: [publications.adda247.com](http://publications.adda247.com) & [store.adda247.com](http://store.adda247.com)  
 For any information, mail us at [publications@adda247.com](mailto:publications@adda247.com)